

# ZVF520

The ZVF520 series frequency inverter is a newly designed, compact and economical solution that is easy to configure, delivers excellent performance, offers a rich feature set, saves energy, provides precise motor speed regulation, and can be used across a wide range of industrial applications



## Main Features

- 01 Realize the programmable relay output delay function.
- 02 NO PG vector control (SVC), V/F control, and torque control.
- 03 Built-in fire mode function, suitable for use in firefighting applications.
- 04 It's convenient for the user to use multiple macro application parameters.
- 05 A wide range of frequency sources combinations for enhanced flexibility of use.
- 06 Built-in PLC function, can realize single cycle shutdown, Retain the final value after a single cycle, continuous cycling and other running mode .
- 07 Can realize static and dynamic motor parameters auto tuning . enabling the inverter to automatically adjust to optimal operating conditions.
- 08 Advanced vector control algorithms adapt to parameter variations caused by motor changes, Improving the system's control inclusivity.
- 09 Multifunctional input terminals supporting both NPN and PNP modes, providing compatible switch signals with any external device.
- 10 Easily realize the inverter with other industrial control equipment such as PLC and industrial control device .
- 11 Multi-layered password protection to safeguard the user rights and interests.

## Demonstration of the Model

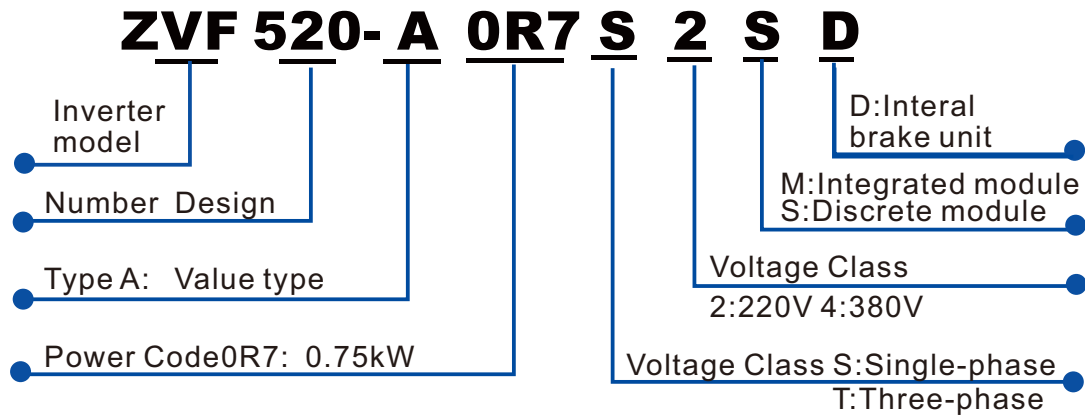

## Inverter Outline & Mounting Dimension (Unit: mm)



Inverter Model	Voltage (V)	Power (kW)	Output Current (A)	Dimension (mm)						Fig.
				H	H1	W	W1	D	d	
ZVF520-A0R4S2	1PH.220-240V	0.4kW	2.3A	146	137	72	63	120	Φ4.5	Fig.1
ZVF520-A0R7S2		0.75kW	4.0A							
ZVF520-A1R5S2		1.5kW	7.0A							
ZVF520-A2R2S2		2.2kW	9.6A							
ZVF520-A3R0S2/T2	1PH./3PH	3.0kW	13A	182	173	87	78	140	Φ4.5	Fig.2
ZVF520-A4R0T2SD	3PH.220-240V	4.0kW	17A	240	229	118	106	165	Φ5.5	Fig.3
ZVF520-A5R5T2SD		5.5kW	25A							

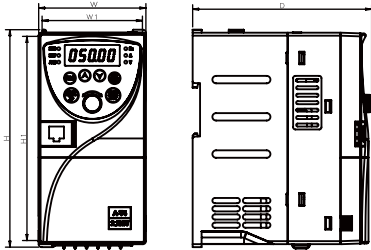

Fig.1

Inverter Model	Voltage (V)	Power (kW)	Current (A)	Dimension (mm)						Fig.
				H	H1	W	W1	D	d	
ZVF520-A0R7T4S	360-440V	0.75kW	2.1A	146	137	72	63	120	Φ4.5	Fig.1
ZVF520-A1R5T4S		1.5kW	3.8A							
ZVF520-A2R2T4S		2.2kW	5.1A							
ZVF520-A3R0T4S		3.0kW	6.8A							
ZVF520-A4R0T4SD	360-440V	4.0kW	9A	182	173	87	78	140	Φ4.5	Fig.2
ZVF520-A5R5T4SD		5.5kW	13A							
ZVF520-A7R5T4SD	360-440V	7.5kW	17A	240	229	118	106	165	Φ5.5	Fig.3
ZVF520-A011T4SD		11kW	25A							
ZVF520-A015T4SD		15kW	32A							

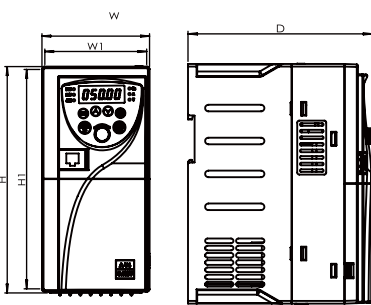

Fig.2

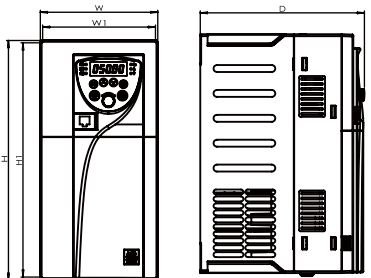
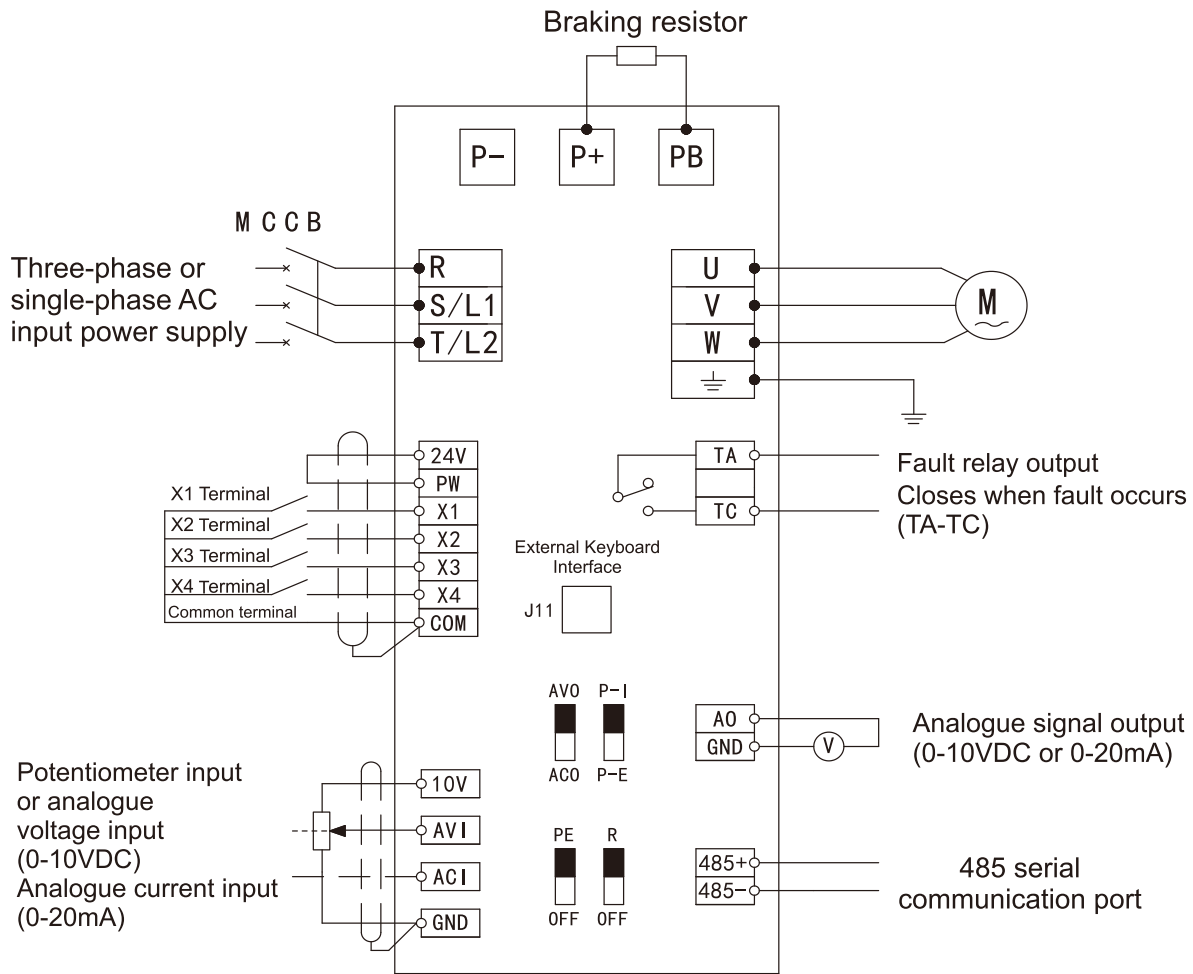

Fig.3

## Technical Indications

item		Description
Input	Rated voltage & Frequency	Three-phase AC360-440V; 50/60Hz Single-phase AC200-240V; 50/60Hz
	Allowable voltage range	Voltage fluctuation range: $\pm 10\%$ Frequency fluctuation: $\pm 5\%$
Output	Rated voltage	Three phase 0~input voltage
	Frequency	0.00 ~ 500.00Hz
	Overload capacity	110% transient protection; 150% 1 minute; 180% 3 seconds
Control performance	Control Mode	V/F Control, Simple Vector Control, Advanced Vector Control, Torque Control
	Frequency	Digital setting: 0.01Hz
	Resolutions	Analogue setting: 0.025% of the maximum output frequency
	Frequency accuracy	Digital setting: 0.01Hz Analogue setting: within 0.2% of maximum output frequency
	V/F voltage frequency characteristic	Three types: the first is linear torque characteristic curve, the second is square torque characteristic curve. and the third is user-set V/F curve.
	Automatic current limiting and voltage limiting	Whether during acceleration, deceleration or stable operation, the motor stator current and voltage are automatically detected and suppressed within the permissible range according to a unique algorithm, minimising the possibility of system fault tripping.
Control performance	Vector voltage-frequency characteristics	The output voltage-frequency ratio is automatically adjusted according to the motor parameters and a unique algorithm.
	Torque characteristics	Starting torque: 100% of rated torque at 5.00 Hz (VF control) 150% of rated torque at 1.00 Hz (Vector control)
	Current and Voltage Suppression	Full current closed-loop control, completely avoiding current surges,, with comprehensive over current and over voltage suppression function
	Undervoltage suppression during operation	Especially for low grid voltage and frequent fluctuations in grid voltage, Even when the voltage is lower than the permitted range.the system maintains the longest possible operating time through unique algorithms and residual energy allocation strategies.
	Slip compensation	Setting range: 0 ~ 100%, according to the motor load can automatically adjust the frequency converter output frequency, reduce the motor with the load changes caused by the rotation speed changes
	Carrier frequency	0.5 ~ 16.0KHz
	Automatic Voltage Regulating Operation	The user can select the dynamic voltage regulation, static voltage regulation,or no voltage regulation three kinds according to the needs, to achieve the most stable operation effects.
	Built-in PID	Can be conveniently configured into closed-loop control systems, suitable for process control applications such as pressure control and flow control.
Operation	Acceleration and deceleration time	0.1 ~ 6500.0s can be set continuously.
	Operation command	Operation panel control, external terminal control, Serial Communication Control
	Frequency setting	Keypad potentiometer setting, panel ▲▼ key setting, external terminal rise/fall setting, analogue voltage or current signal setting, terminal combination setting, serial communication setting, etc.
brakes	Output Signal	One programmable relay output, one analogue output
	Energy consumption braking	Energy consumption braking start voltage, differential voltage and energy consumption braking rate are continuously adjustable.
	DC braking	Starting and stopping can be selected, action frequency 0.0 ~ upper limit frequency, action current level 0 ~ 50%, action time 0 ~ 30s, continuously can be set
	Other Functions	Upper and lower frequency limit, reverse operation limit, Jog function, counter, Skip frequency operation. instantaneous power failure and restart. fault automatic reset. etc.
	Protection function	Overcurrent, Overload, overvoltage, undervoltage, overheat, short circuit, etc.
	LED display	Real-time display of inverter operation status, monitoring parameters, functional parameters, fault code and other information.
	Optional Parts	Brake assembly, remote operation panel and connection cable

## ZVF520 Inverter 's Wiring Diagram



## Application



Leading Automation Control Solution Provider  
 ZHEJIANG ZIRI ELECTRICAL TECHNOLOGY CO.,LTD.  
 Tel:0086-577-27863300 Fax:0086-577-27872255  
 E-mail:chziri@chziri.com  
 Add: NO.62-70, DaQiao Road. Liushi.WenZhou, 325604, Zhejiang. China

